

# IC 18-24



## Automatic ice cube maker - spray system.

Quality cubes: compact, cold and crystalline.

Suitable for embedment, with ventilation and controls at the front.

The ice produced drops into the collection bin and is ready to meet the ice requirements even at peak demand times.

## Produttori automatici di ghiaccio in cubetti - sistema a spruzzo.

Cubetti di qualità: compatti, freddi e cristallini.

Adatti all'incasso, ventilazione e comandi frontali. Il ghiaccio prodotto cade nel contenitore di raccolta pronto a soddisfare le esigenze di ghiaccio nelle ore di maggiore richiesta.



IC 18



IC 24

---

---

---

---

---

---

---

---

---

---



# IC 18-24

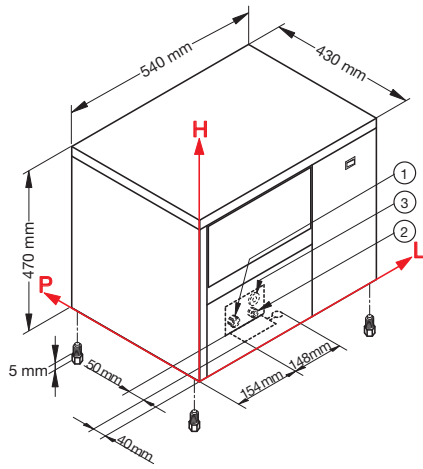

IC 18

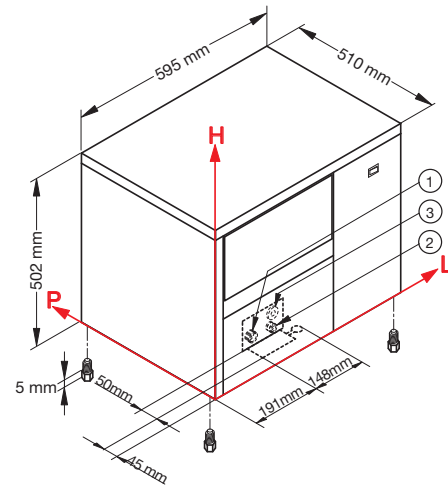

IC 24

CONNECTIONS / CONNESSIONI	IC 18			IC 24		
	L	H	Ø	L	H	Ø
① Water inlet / Ingresso acqua	-	-	3/4"	-	-	3/4"
② Water outlet / Scarico acqua	-	-	24 mm	-	-	24 mm
③ Electrical connection / Connessione elettrica	-	-	-	-	-	-

TECHNICAL INFORMATION / DATI TECNICI	IC 18	IC 24
Production in 24 h / Produzione in 24 h	21 kg	24 kg
Storage capacity up to / Capacità contenitore fino a	4 kg ≈ 310 □	6 kg ≈ 350 □
Cooling system / Condensazione	A	A
Kind of cube / Tipo di cubetto	D-13g	A-18g D-13g
Refrigerant / Refrigerante	R404A	R404A
Standard voltage / Voltaggio standard	220-240 V ~ 50 Hz	220-240 V ~ 50 Hz
Electrical consumption / Consumo elettrico	320 W	350 W
Fuse / Fusibile	10 A	10 A
Water consumption (l/kg) / Consumo acqua (l/kg)	A 4,5	A 5,1
Sizes (WxDxH) / Dimensioni [ LxPxH ]	540x430x470 mm	595x510x502 mm
Sizes with packing (WxDxH) / Dimensioni con imballo [ LxPxH ]	590x490x640 mm	635x555x675 mm
Weight (net/gross) / Peso [ netto/lordo ]	34/39 kg	41/48 kg

Finishing 18/8 stainless steel, scotch brite / Finitura acciaio inox 18/8, scotch brite

Gli apparecchi sono da considerarsi in Classe tropicale (Temperatura ambiente fino a 43°C). / The equipment are to be considered in tropical class (ambient temperature up to 43 °C).

INSTALLATION CONDITIONS / CONDIZIONI D'INSTALLAZIONE	Min / Max
Installation / Installazione	indoor / interna
Ambient temperature / Temperatura ambiente	+10 / +43 °C
Water temperature / Temperatura acqua	+3 / +32 °C
Voltage / Voltaggio	± 10%
Water inlet pressure / Pressione dell'acqua in ingresso	1bar (14psi) / 6bar (84psi)

CONDITIONS / CONDIZIONI	
Standard Cube / Cubetto standard	13g IC 18 - 18g IC 24
Ambient temperature / Temperatura ambiente	+21°C
Water temperature / Temperatura acqua	+15°C
Electrical consumption at +43°C (standard voltage) / Consumo elettrico a +43°C (voltaggio standard)	